

LOC HQ DIST 00

REVISIONS

P	LTR	DESCRIPTION	DATE	DWN	APVD
	G1	REVISED PER ECO-11-005027	12MAR2011	RK	HMR

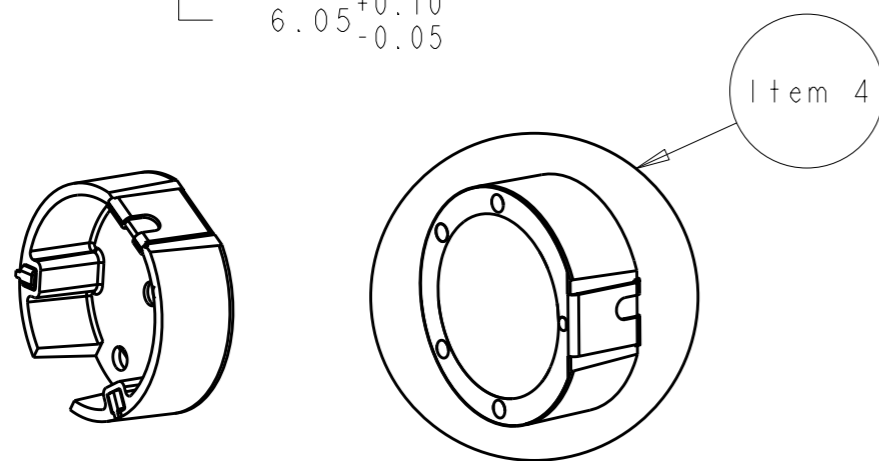
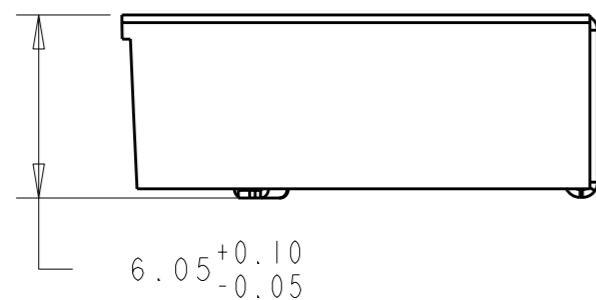
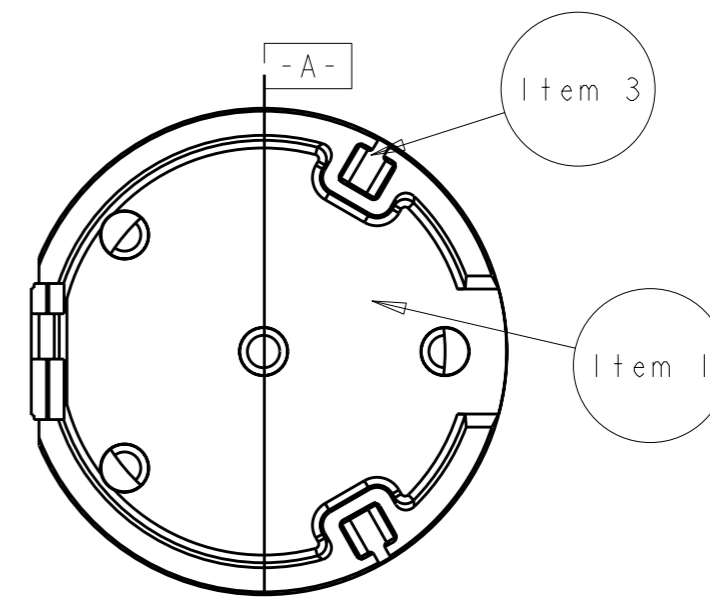
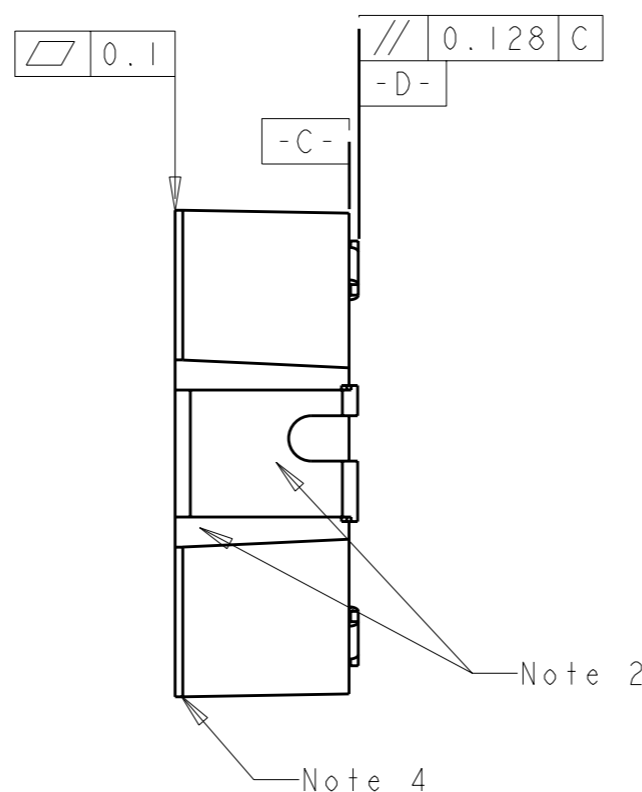
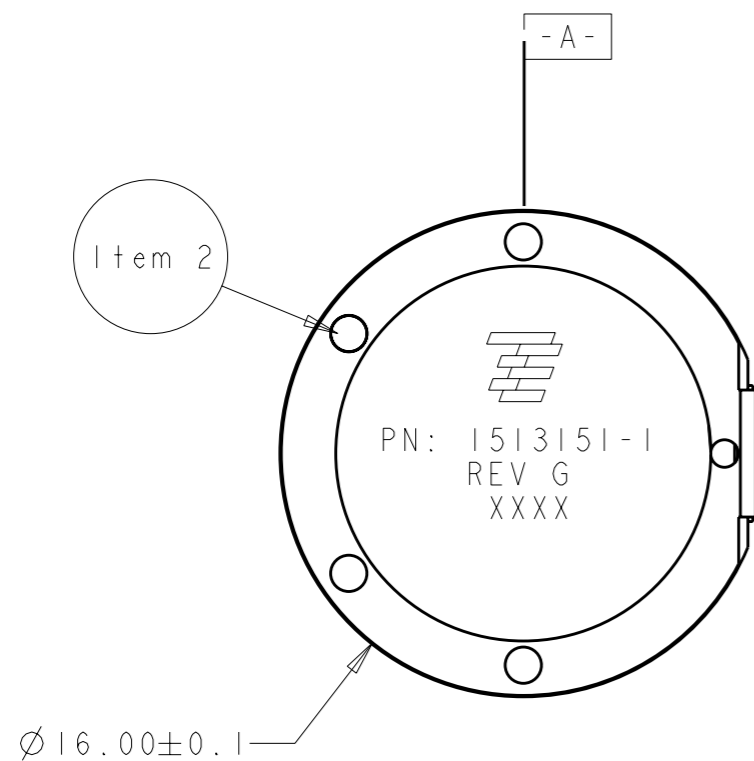

1513151-1
SCALE 2:1

NOTES:

1. Material - Dow Questra WA550, 30% glass filled, natural color.
2. Item 2 insert molded into Item 1. Flat side wall of Item 2 to be flush with flat side wall in Item 1.
3. Item 3 press fit into Item 4.
4. No air gaps between components
5. General tolerance block applies unless otherwise specified.

ITEM NO.	QTY.	DESCRIPTION
1	1	OVERMOLDED METAL RING
2	1	METAL RING
3	2	ANCHOR TAB
4	1	ASSEMBLY

THIS DRAWING IS A CONTROLLED DOCUMENT.		DWN DJL 06OCT2003	STE TE Connectivity			
DIMENSIONS: mm		CHK -				
TOLERANCES UNLESS OTHERWISE SPECIFIED:		APVD -	NAME Antenna Bluetooth/WLAN			
0 PLC ±0.10		PRODUCT SPEC -				
1 PLC ±0.10		APPLICATION SPEC -	SIZE A3	CAGE CODE 00779	DRAWING NO. C-1513151	RESTRICTED TO -
2 PLC ±0.05		WEIGHT -	CUSTOMER DRAWING			
3 PLC ±0.05		SCALE 4:1				
4 PLC ±0.01		SHEET 1 OF 1				
ANGLES ±1°		REV G1				
MATERIAL -						
FINISH -						